

INSTALLATION INSTRUCTIONS

F15FMP-SS / F15FMP-SY / F20FMP-SS /
F20FMP-SY / F30FMP-SS / F30FMP-SY

FURRION

WIRING INSTRUCTIONS:

- Strip conductor and jacket using strip gage on device
- Loosen Terminal Screws.
- Insert conductors fully into copper terminals as below.
- Take caution that there are no stray wire strands.
- Tighten terminals screws 14~16 in-lbs torque.
- Use copper conductors only

MARKING:

G = Green or Green/Yellow

W = White

X, Y, Z or blank = Other than White or Green or Green/Yellow

DIMENSIONS OF STRIP CONDUCTOR AND JACKET:

The length of strip conductor: 16mm (5/8" Inches)

The length of strip jacket: 40mm (1½" Inches)

EXPLODED VIEW

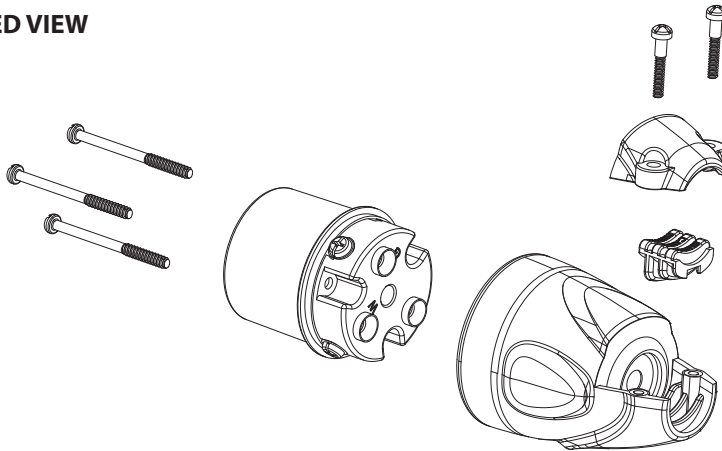

WARNING:

- For installation by a qualified electrician in accordance with national and local electrical codes and the following instructions.
- Check that the device's type and rating are suitable for the application.
- Risk of electric shock. Disconnect power before installing.
- Terminal capacity: 12AWG to 10AWG for 20Amp; 10AWG for 30Amp

